

User Manual for all Dualtec Cushions (product code begins with '1101')

Revision: DualtecCushion20210501\_EN



# spex

Dualtec Cushion  
*Installation & User Manual*

**IMPORTANT CONSUMER INFORMATION NOTICE:**

This manual contains important instructions that must be passed on to the user of this product. Please do not remove this user manual before delivery to the end user.

**SUPPLIER:** This manual must be given to the user of this product.

**USER/CAREGIVER:** Before using this product, read entire manual and save for future reference. Transit Safety section **MUST** be read before cushion is used in a vehicle.

User Name:

Serial Number:

# Introduction

The Dualtec Cushion is a basic and adjustable cushion for symmetrical sitting postures. It is designed for supporting the pelvis and legs correctly and offering skin protection.

Note: Check all parts are free from shipping damage. Contact Spex or your supplier for further instructions if needed. Spex recommends that a clinician such as an Occupational Therapist or Physiotherapist who is skilled in wheelchair seating and positioning be consulted to determine if the Dualtec Cushion is appropriate for the user. The intended user of the Dualtec Cushion is a user with postural support requirements.

# Safety Instructions

To avoid injury, read, understand and follow all instructions and warnings in this manual before installing and using the Dualtec Cushion. There are hazards associated with the use of wheelchairs and adaptive equipment. If you misuse your wheelchair or your Cushion you can be seriously injured. If your Cushion ceases to function as intended, please consult your authorized Spex seating supplier immediately before continuing to use.

The cover and foam meet the flammability requirements of California Technical Bulletin 117. In rare cases the fabrics used in this product may cause a skin irritation for people with sensitive skin. If you experience any reddening or itching of the skin consult with your health care professional.

***Disclaimer: Spex takes no responsibility as to the therapeutic effectiveness of our products. Our claims relate to the ability of the products to provide safe and reliable positioning and seating on the equipment onto which they are installed.***

# Weight Capacity

- 10-15" (25.4 - 38 cm) Cushion maximum user weight: **150 lbs. (68kg)**
- 16-20" (41 - 51 cm) Cushion maximum user weight: **250 lbs. (112 kg)**



## WARNING

Never exceed the weight capacity of your cushion or the wheelchair as specified by the wheelchair manufacturer. Never perform exercise weight training that causes the user to exceed the weight capacity of the wheelchair.

# Environment

**Moisture:** Keep your Cushion dry at all times, as contact with water or excess moisture could cause degradation to the functionality of your Cushion, or potential failure. If your Cushion becomes damp or wet, thoroughly wipe with a dry cloth as soon as possible. Do not use your Cushion in a showering or pool facility.

**Temperature:** Your Cushion may not function as intended when used at extreme temperatures. Keep the Cushion away from sources of extreme heat or extreme cold to avoid change in functionality of the foam.

**Dirt:** Small particles such as dust, dirt and sand may restrict optimum functionality. Regularly wash your Cushion cover to ensure no build-up occurs.

# Cushion Contents

Your Cushion contains the following:

	Description	Quantity
A	Incontinence cover	1
B	Foam Unit	1

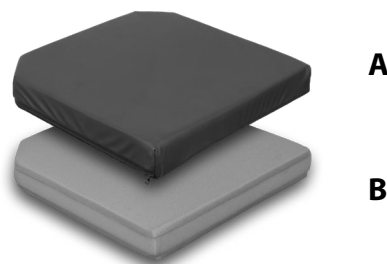

# Disposal & Recycling

Your Spex Seating System is manufactured using a variety of materials, most of which can be recycled. Once it reaches the end of its life, if you are the legal owner, do not dispose of as ordinary household waste but take your Spex System to an approved recycling or collection point, to dispose of according to local laws and regulations.

Separate collection and recycling of the Spex System when disposing ensures protection of the environment and assists with natural resource conservation.

# Compatibility

- The Dualtec Cushion has been designed to be compatible with most wheelchairs.
- The Dualtec Cushion must have a solid base to install to, such as a solid seat base pan or cushion rigidizer, which provides more stability to the user.



## WARNING

### **RISK OF ACCIDENT, INJURY, PAIN OR DEATH IF WARNINGS ARE NOT HEEDED**

*Seek assistance if you are uncertain about any of the following points*

- 1. Installing a Cushion on a wheelchair may disturb the wheelchair's centre of gravity and cause the wheelchair to tip backwards potentially resulting in injury or death. Check if anti-tippers or other adaptations need to be added to the wheelchair to help increase stability.**
- 2. Installation and adjustment of your Dualtec Cushion must only be performed by**
  - a) An authorized Spex distributor or technician**
  - b) A qualified healthcare professional who has undergone appropriate biomechanical training**
- 3. The Dualtec Cushion must have a solid base to install to. A solid seat base pan will provide more stability to the user (the Cushion won't sag).**
- 4. This Cushion must be trialled first to determine its effectiveness in meeting the needs of the user. The clinician must inspect the user's skin to ensure that red pressure spots are not developing.**
- 5. The user and/or caregivers should regularly check for skin redness or tissue breakdown. If redness develops, discontinue the use of the Cushion immediately and consult your doctor or therapist. The Cushion can be reconfigured for better positioning.**
- 6. With proper set-up and continued maintenance, the Dualtec Cushion is an excellent candidate for people who are at risk of skin ulcers, however no Cushion can completely eliminate sitting pressure or prevent pressure ulcers.**
- 7. Keep the Cushion dry. Moisture is a contributing factor in causing pressure ulcers.**
- 8. We recommend the user to have a good diet and have regular pressure relieving exercises/therapy to help prevent pressure ulcers.**
- 9. Do not leave the Dualtec Cushion outside overnight or at temperatures below 5° C/41° F. The Dualtec Cushion should be room temperature before sitting on it.**
- 10. Avoid sharp objects or exposure to excessive heat or open flame.**
- 11. The Dualtec Cushion has been specifically designed as a Cushion for users in mobility wheelchairs. Do not use the Cushion in any way not described and never modify the Cushion.**
- 12. Care should be exercised near open flame or burning cigarettes. Using the Cushion without its cover increases the risk of flammability and skin damage.**
- 13. Never use the Cushion without the incontinence cover. Failure to do so will reduce the life of the Cushion.**

# Maintenance & Cleaning

Monthly cleaning and regular maintenance will help extend the life of the Cushion. The expected lifetime of the Cushion is 5 years; however the Cushion needs to be checked regularly for performance.

Spex recommends using AHP (Accelerated Hydrogen Peroxide) disinfectant wipes. The disinfection product must be used as per the manufacturer instructions. Spex takes no responsibility for the effectiveness of the disinfecting process.



## WARNING

- Replacing the cover after washing must be done correctly. Ensure the back of the cover matches up to the back of the foam base.
- If used in an institutional setting, write the resident's name with a permanent marker on the content label of the covers. This will help to ensure the return of the covers after washing.
- Use only Spex Covers on Dualtec Cushions. Changing the Cover, or using different materials, will alter the design and may cause harm or pressure concerns to the user.

## Foam

- Keep dry.
- Check the foam base regularly to ensure good foam consistency.
- If it accidentally becomes wet, dry thoroughly before replacing the covers.

## Incontinence Cover

- Hand wash only.
- Do not use bleach or other strong cleaners.
- Do not tumble dry.
- Failure to use this cover may reduce the life of the cushion.

## Spex Outer Cover (if installed)

- Remove the cover from the foam base and turn inside out.
- Machine wash in warm water (40° C / 104° F)
- Drip or tumble dry on low heat.
- Do not iron. Do not dry clean. Do not bleach.
- If chemical cleaners are used, covers must be rinsed thoroughly with water to remove all chemical residue and left to dry completely before reuse.
- Check the cover for tears and excessive wear and replace if ripped, torn or otherwise not fully functional.

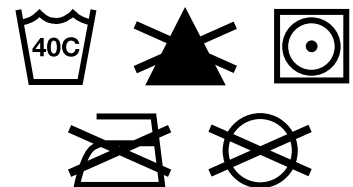

If you have any additional questions regarding cleaning procedures, please contact your authorized Spex Seating dealer.

# Transit Safety

The Spex Seating System has been successfully crash tested and complies with RESNA WC-4:2012, Section 20 (WC20). The Spex Seating System meets the requirements of ISO 16840-4:2009 and is suitable for use as a motor vehicle seat when used with an appropriate wheelchair base. Please follow all installation, use and maintenance instructions within this manual as well as the following transit instructions. If feasible, the wheelchair user should transfer to the vehicle seat and use the vehicle-installed occupant restraint systems.

Spex Seating System has been designed to accommodate the proper use of vehicle-anchored belt restraints. Spex achieved a rating of Excellent (16 out of 16), for ease of properly positioning a belt restraint, and the degree to which proper belt restraint can be achieved, based on the methods of Annex D. The following items of the Spex Seating System have been tested and are suitable for use in a motor vehicle:

- Full Height Back Support Models
- Seat Base
- Cushion Models
- Arm and Thigh Supports
- Trunk Lateral Supports
- Head Supports

Note: Back supports that are lower than the user's shoulder height are not certified and not recommended for transport in a vehicle. Eg. Vigour Lo and Vigour Mid back supports.

## Assembly, Use, Maintenance & Limitations

- Adjustments to the set-up of the wheelchair must only be carried out by a qualified therapist, professional, or seating technician. Custom contoured/bespoke systems may require a qualified professional to configure and install the seating system.
- After carrying out any adjustments ensure all bolts, screws and nuts are securely fastened again to ensure safety when travelling in a vehicle.
- Ensure the top and bottom mounts of the backrest and the front and rear mounts of the seat pan are installed as far apart from each other as possible to give a stronger 4-point attachment to the wheelchair frame. Ensure the quick release latches are engaged.
- Do not use the Spex Seating System as a vehicle seat if seating components which have not been successfully crash tested are used anywhere on the seating system. Spex seating is designed and certified using only Spex components. Spex is not liable in the event where other manufactured seating systems are used in conjunction with Spex seating.
- At regular intervals check that all the fastenings on the Spex Seating System have not become loose during day to day use and re-tighten if necessary.
- Ensure the swing-away laterals are in their locked position before using the seat as a vehicle seat in a motor vehicle.

# Transit Safety

## Correct Positioning of Belt Restraints

When using the Spex Seating System as a vehicle seat, both a pelvic-belt restraint and shoulder-belt restraint must always be used. To correctly position the belt restraints on the wheelchair occupant, the following must be ensured:

- The pelvic-belt restraint should be worn low across the front of the pelvis near the junctions of the pelvis and thighs.
- The angle of the pelvic-belt restraint should be between 30° to 75° relative to the horizontal and, ideally, between 45° to 75° to the horizontal (as shown in Figure 2).
- The belt-restraint buckle of three-point belt restraints should be placed in contact with the occupant’s body and away from wheelchair components.
- The junction of the shoulder-belt and pelvic-belt of three-point-belt restraints should be located near the hip opposite the shoulder over which the diagonal belt crosses and not near the midline of the occupant.
- Belt restraints should not be routed outside of the wheelchair wheels or over the wheelchair armrests, and should not be held away from the body by wheelchair components or parts.
- Upper torso belt restraints should fit directly over, and in contact with, the middle of the shoulder.
- Belt restraints should be adjusted to fit as snugly as possible, consistent with user comfort.
- Belt restraints should not be worn twisted in a manner that reduces the area of contact of the belt webbing with the occupant.



Figure 1

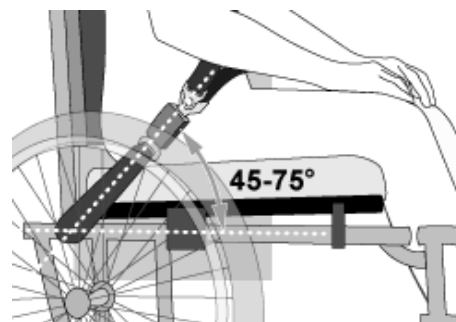

Figure 2



Figure 3a - Improper positioning of pelvic-belt restraints over wheelchair supports.

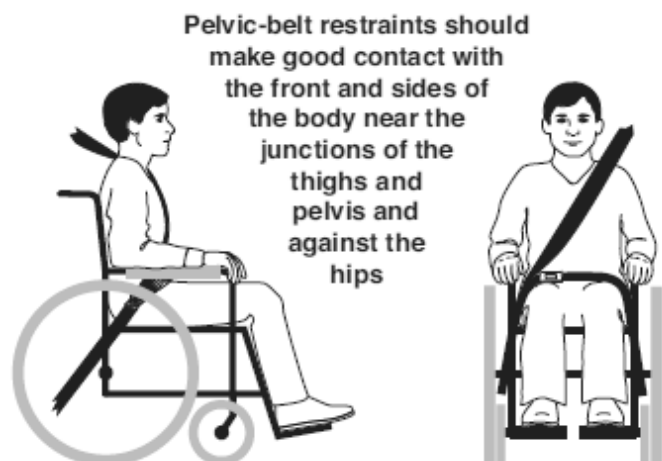

Figure 3b - Proper routing and positioning of belt restraints on the wheelchair occupant.

**WARNING**

- 1. The distance between the top of the user's shoulder and the top of the back should not exceed 6.5" (16.5 cm).**
- 2. The Spex Seating System must only be used with wheelchair bases that are tested as part of a wheelchair system that conforms to performance requirements of ISO 7176-19 and RESNA WC-4:2012, Section 19.**
- 3. The Spex Seating System should only be used on wheelchair frames that provide four securement points and pelvic-belt anchor points that conform to the requirements of RESNA WC-4: 2012, Section 19.**
- 4. The wheelchair must be labelled as appropriate for use as a seat in a motor vehicle, dynamically tested to the performance requirements of ISO 7176-19 and installed, used and maintained according to the manufacturer's instructions.**
- 5. The Spex Seating System must only be used as indicated in this user manual.**
- 6. Both pelvic and shoulder-belt restraints as a part of a complete Wheelchair Tie down and Occupant Restraint System (WTORS) which meets ISO 10542-1 shall be used to achieve effective occupant restraint and optimum protection in a vehicle impact; the belt restraints should be compatible with the specific wheelchair, and fitted to the user in accordance with WTORS manufacturer's instructions.**
- 7. Back supports with adjustable recline angles should not be tilted back more than 30° beyond the vertical during travel in vehicles unless necessary for the medical and postural needs of the occupant.**
- 8. If the back support must be adjusted to an angle that is greater than 30° beyond the vertical during travel, the upper shoulder-belt anchor point should be adjusted rearward to maintain belt**



**WARNING**

8. cont... contact with the wheelchair occupant's shoulder and chest.
9. The Spex Seating System must only be used for forward-facing seating in motor vehicles.
10. In order to reduce the potential of injury to vehicle occupants, wheelchair-mounted rigid trays not specifically intended for use during travel in motor vehicles must be:
  - a. Removed and secured separately in the vehicle or
  - b. Secured to the wheelchair so they will not break free in a crash and
    - Be positioned with a gap of at least 3" (75 mm) between the back edge of the tray and the wheelchair occupant's abdomen and/or chest so as not to interfere with the proper belt-restraint use, and
    - Have energy absorbing padding placed between the back edge of the tray and the wheelchair occupant.
11. Alterations or substitutions must not be made to the seating system structure, parts or components, without first consulting Spex.
12. The use of a postural pelvic belt attached to the wheelchair base or seat frame is encouraged during travel, but these belts should be positioned so that they don't interfere with the proper positioning of crashworthy belt restraints, and they should not be relied on for occupant protection in crash situations unless the postural belt has been designed to comply with, and perform to the requirements of WC19.
13. Postural support devices that are not labelled as conforming to ISO 16840-4 may be used when in a vehicle, but should not be relied on for occupant restraint.

**WARNING**

14. Both pelvic-belt and shoulder-belt restraints that comply with WC18 and/or WC19 should be used to limit occupant movement in a crash and reduce the likelihood of occupant ejection from the vehicle and/or injurious contact of the occupant with the vehicle interior.
15. Belt restraints should be positioned on the wheelchair occupant in accordance with WTORS manufacturer's instructions.
16. Backrest mounting hardware must be installed correctly. Refer to the appropriate section for correct backrest hardware mounting instructions.
17. If the wheelchair is being transported while occupied, the wheelchair must still be secured to the WTORS.
18. Children whose mass is less than 48.5 lbs. (22 kg) should be transferred from their seating system into appropriate child restraint systems intended for use in motor vehicles.
19. Sufficient forward and rearward clear space should be provided around the wheelchair occupant. Forward clear-space zone (FCZ) needs to be larger when a shoulder-belt restraint is not used.

**FAILURE TO HEED THESE WARNINGS COULD  
CAUSE SEVERE INJURY TO THE WHEELCHAIR  
USER OR OTHERS.**

 **WARNING**

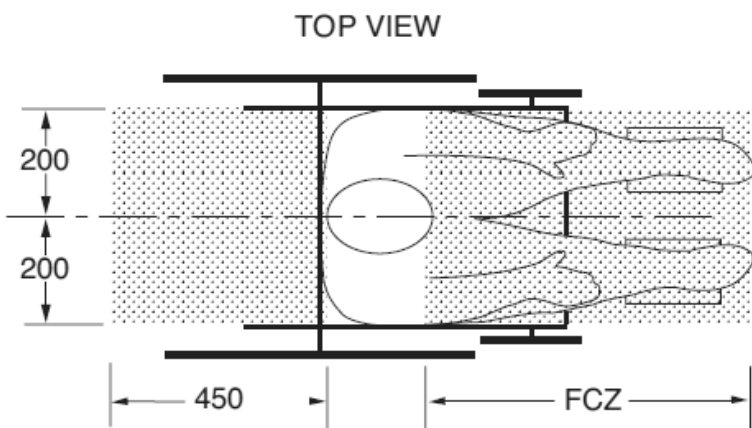

NOTES: The rear clear zone is measured from the rearmost point on an occupant's head. The front clear zone is measured from the frontmost point on an occupant's head.

Seated head height (HHT) ranges from about 47" (1200 mm) for a small adult female to about 61" (1550 mm) for a tall adult male.

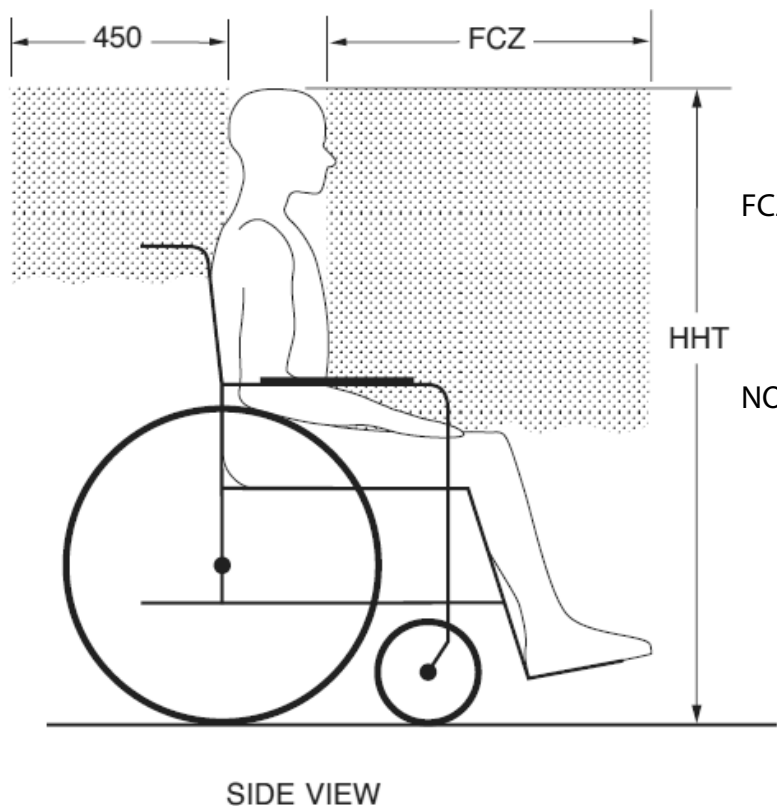

FCZ = 25.5" (650 mm) with upper torso restraint  
 = 37" (950 mm) with only pelvic restraint

NOTE: It is strongly recommended that both pelvic and upper torso belts be used.

Recommended forward and rearward clear zones for wheelchair seated occupants. (Note: the FCZ may not be achievable for wheelchair seated drivers).

# Warranty

Every DualTec cushion is inspected to provide optimum performance. Each cushion is guaranteed to be free from defects for a period of 12 months from the date of purchase, provided normal use. Should a defect in materials or workmanship occur within 12 months of the original date of purchase, Spex Limited will, at its option, repair or replace it free of charge. This warranty does not apply to punctures, tears or burns, nor to the cushion’s removable outer cover or inner incontinence cover.

Claims and repairs should be processed through the nearest authorized Spex supplier. Except for express warranties made herein, all other warranties, including implied warranties of merchantability and warranties of fitness for a particular purpose are excluded. There are no warranties which extend beyond the description on the face hereof. Remedies for breach of express warranties herein are limited to repair or replacement of the goods. In no event shall damages for breach of any warranty include any consequential damages or exceed the cost of non-conforming goods sold.

The serial number of your Cushion can be located at the rear of the Cushion cover.



32 Detroit Drive  
 Rolleston 7675  
 New Zealand



Spex Ltd  
 Phone +64 3 307 9790  
 Fax +64 3 307 2820  
[fasterresults@spexseating.com](mailto:fasterresults@spexseating.com)  
[www.spexseating.com](http://www.spexseating.com)

US	REP
Medicept 200 Homer Ave, Ashland, MA 01721 United States Tel: +1-508-231-8842	

EC	REP
BEO MedConsulting Berlin GmbH Helmholtzstr. 2 D-10587 Berlin, Germany Tel: +49-30-318045-30	