

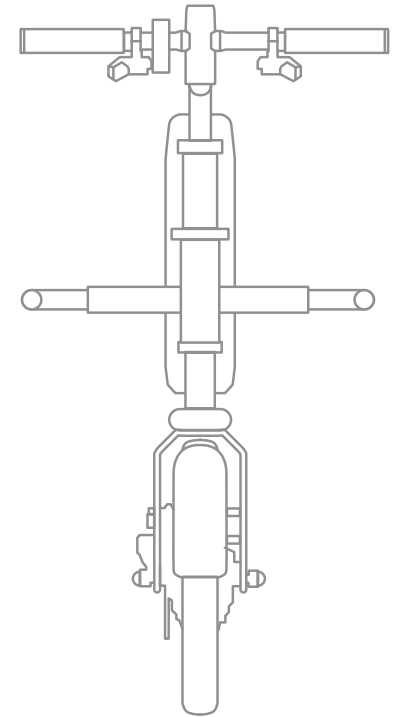

EXTRA POWER FOR YOUR WHEELCHAIR

HIGH
PERFORMANCE



EXPLORE LIKE NEVER BEFORE WOR

YOUR PERFECT COMPANION EITHER IN THE COUNTRYSIDE OR IN THE CITY



PLACES THAT USED TO BE OUT OF REACH

Smartly designed to provide you that extra bit independence and carelessness, the Empulse F55, as a new member of our e-mobility family, allows you to extend your personal range, to save your strength and to experience pure driving pleasure.

Ultra-compact and easy to dock so you can upgrade your wheelchair with that extra power whenever it is needed. The ideal solution when you don't want to use your car and for a more environmentally friendly solution – or if you just want to have fun.



**ENJOY
THE
RIDE**



**HAVE
FUN**



GOES WHEREVER YOU WANT TO GO

Life in the city is dynamic and vibrant. Keep up with it, enjoy mobility and flexibility. Narrow lifts, narrow streets, narrow corridors in the supermarket? No big deal thanks to a super small turning circle.

Activate the cruise control and do not care about using the throttle lever all the time. The Empulse F55 will hold the selected speed for more easing for you. You would like to be a little further away? No worries, the IATA certified battery simplifies your travelling.

With the Empulse F55 you can make your way and focus on the essentials. Meeting your friends at the cafe, for example.



MOBILITY HAS NEVER BEEN SO EASY



The powerful brushless electric motor and the optimised traction will help you tackle almost every terrain.

**NO
LIMITS**

POWERBANK

8.1 Ah capacity Li-Ion battery for up to 25 km of range and with an intelligent battery management system for improved charging cycles and lifetime.

TRACTION

Is what matters most on steep uphill sections. The fully adjustable Empulse F55 lets you adjust weight balance and optimise traction.

IT'S UP TO YOU

Whether you want to manoeuvre your Empulse F55 through the urban jungle with the 8,5" wheel or enjoy the increased ride comfort of a 14" wheel.

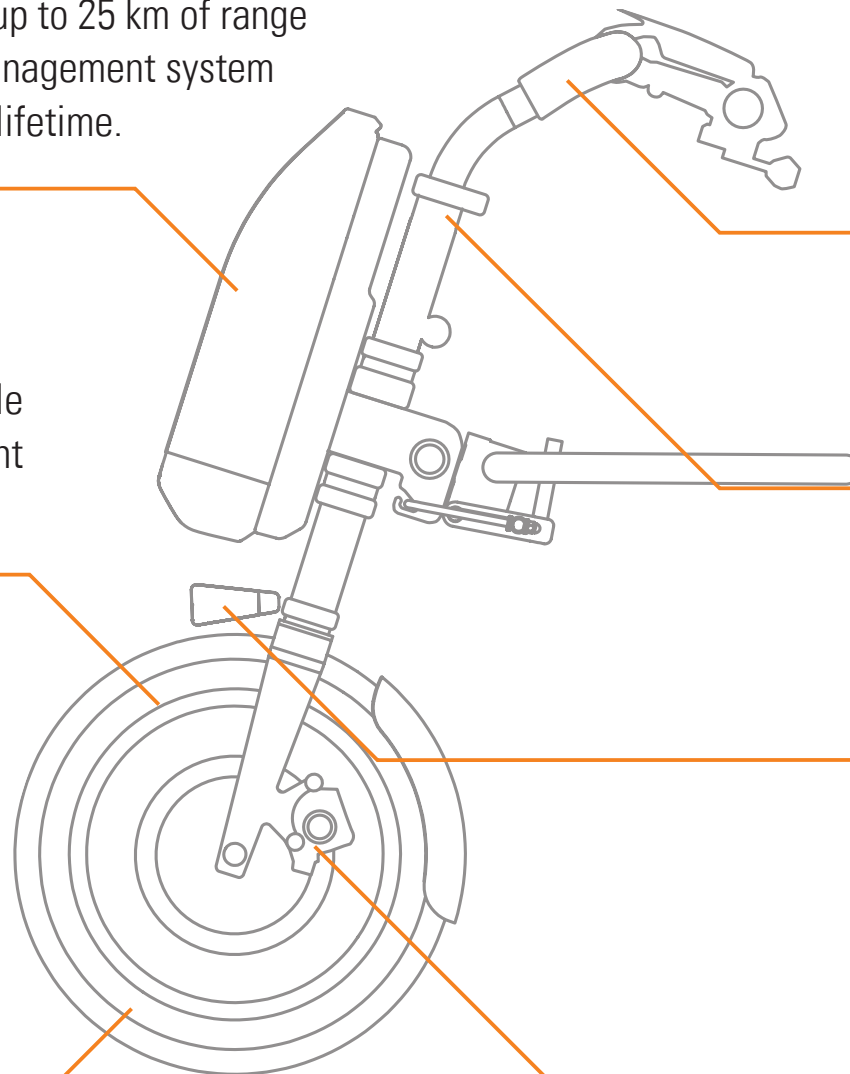

DISPLAY

Full control with the easy to read display: speed mode, trip distance, total distance, battery condition, power consumption.

RIDE COMFORTABLY

On-the-fly adjustability for the position of the handlebar.

LIGHTS YOUR PATH

LED front light is a standard option on the Empulse F55.

UNSTOPPABLE – UNLESS YOU WANT TO

Two independent brake systems for increased safety: non-wearing electric brake or powerful disc brake.

AT YOUR SIDE WHENEVER IT MATTERS – OUT OF THE WAY WHENEVER YOU WANT IT

YOU'RE JUST A FEW SE- CONDS AWAY ...

... from your urban and outdoor adventures: With the easy-to-use docking-mechanism, your Empulse F55 can be docked to all types of wheelchairs and within seconds and becomes a powerful companion in your daily life.



Drive wheel 8,5", solid tyre,
docking for fixed-front wheelchairs



Drive wheel 14", pneumatic tyre,
docking for fixed-front wheelchairs



Drive wheel 8.5", solid tyre, docking for
swing-away wheelchairs with longer sub
frame tubes and swannecked steering tube



OUT YOU GO



Thanks to the flip up sub frame, the Empulse F55's pack size can be minimised within seconds: flip the frame, insert the steering tube and you will get a handy package that can be stowed away easily. If necessary, the sub frame can even be fully detached.



SHOW YOUR COLOURS

FOR
FREE



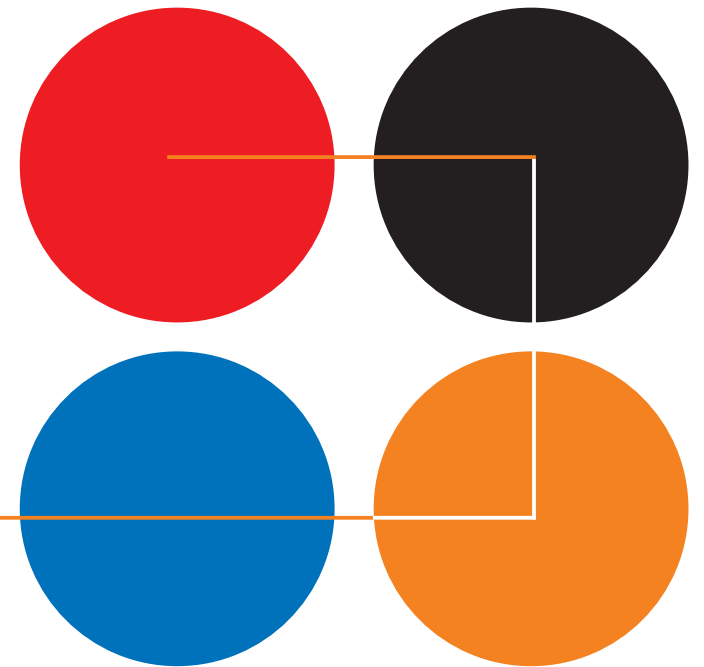

Individualisation made easy with the easy-to-change colour kits for fender and sidebars: black, blue, red and orange come as standard and can be changed quickly.



TECHNICAL DATA OVERVIEW

Empulse F55

Operating Voltage	36 Volt
Range of action	25 km max.
Climbing power	up to 11% (6°)
Front frame width	260 – 480 mm ⁽¹⁾
Max. user weight	110 kg
Max. speed forward	6 kph; optional 10 kph or 15 kph
Battery weight	2 kg
Wheel size	8,5" air-chambered solid-tyre / 14" pneumatic tyre
Total weight w/o battery	11 kg
Battery type	Lithium-ion, 36V, 8.1 Ah
Total weight with battery	From 13 kg
Brake type	Twin-brake system: mechanical disc-brake and separate electric brake
Colour	black
Colour accents (included in delivery)	black, red, blue, orange (black mounted as default)

(1) Frame width measured from center frame tube to center frame tube at the mounting position. Use only the measured dimension and not the seat width to check compatibility.

For further information on the full specification, options and accessories, please refer to the order form. All information is subject to change without notification. Please consult Sunrise Medical with any queries you may have. If you are visually impaired, this document can be viewed in PDF format at www.SunriseMedical.eu.



Sunrise Medical GmbH

Kahlbachring 2-4
69254 Malsch/HD
Tel.: +49 (0) 72 53 / 9 80-0
Fax: +49 (0) 72 53 / 9 80-222
E-Mail: international@sunrisemedical.de
www.SunriseMedical.eu

